

## Design a prototype of a marine wave power plant (PLTGL) using a recoil starter

Fauzi Farhan<sup>1</sup>, Abdul Z. Patiran<sup>2</sup>, Henny A. B. Lesnussa<sup>3,\*</sup>, Adelhard Beni Rehiara<sup>4</sup>, Pandung Sarungallo<sup>5</sup>, and Yanty Rumengan<sup>6</sup>

<sup>2,3,4,5,6</sup> University of Papua, Instrumentation and Control Research Group, Department of Electrical Engineering, Faculty of Engineering; 98314, Manokwari, Indonesia.

<sup>1</sup> University of Papua, Department of Electrical Engineering, Faculty of Engineering; 98314, Manokwari, Indonesia.

\* Correspondence: [h.lesnussa@unipa.ac.id](mailto:h.lesnussa@unipa.ac.id)

Received Date: May 20, 2023

Revised Date: July 31, 2023

Accepted Date: July 31, 2023

### Cite This Article:

Lesnussa, H., Farhan, F. ., Patiran, A. Z. ., Rehiara, A. B. ., Sarungallo, P. & Rumengan, Y. .(2023). Design a prototype of a marine wave power plant (PLTGL) using a recoil starter. *Journal of Innovation Materials, Energy, and Sustainable Engineering*, 1(1). 35-49. <https://doi.org/10.61511/jimese.v1i1.2023.37>



Copyright: © 2023 by the authors.  
Submitted for possible open access article distributed under the terms and conditions of the Creative Commons Attribution (CC BY) license (<https://creativecommons.org/licenses/by/4.0/>)

### Abstract

As the needs of human life increase, the need for electrical energy will also increase. Currently, fossil energy, which is widely used as fuel for the provision of electrical energy, is running low. In Indonesia, renewable energy sources have not been utilized properly, such as wave energy. This study discussed how to design a prototype of a sea wave power plant. The problem is, how to be able to utilize the energy of sea waves to the maximum. The purpose of this research is to find solutions and designs to utilize recoil starter as a prototype of ocean wave power plants. The methodology used in this study is an experiment in which the prototype made is given a certain treatment and then measurements are made. His data analysis technique is descriptive analysis. Based on the results of measurements and observations, the performance of the tool is not only influenced by the height of the wave, but also the period of arrival of the sea wave and the ballast load of the tool. After measurements were made on the first day of Maruni beach, the prototype could produce an average power of 4.21 watts for an average wave height of 0.35 m and Maruni beach on the second day could produce an average power of 5.68 watts for an average wave height of 0.4 m. While on the first day Amban beach obtained an average power of 3.29 watts for an average wave height of 0.37 m and Amban beach on the second day could produce an average power of 14.26 watts for an average wave height of 0.5 m.

**Keywords:** ocean waves; PLTGL prototype design; recoil starter

## 1. Introduction

Indonesia is an archipelagic country whose territory is mostly sea. Natural wealth that is a source of livelihood for Indonesian fishermen. However, the use of natural wealth is still very minimal and has not been fully utilized by the government as an energy source. The sea can be used to produce energy including wave energy, tidal energy, ocean energy, and ocean thermal energy. With the depletion of fossil fuels on earth, to solution the problem is to utilize energy that can be produced from the sea (Sulasno, 2013).

Requirements for electrical energy has become very important for human survival. This is because in daily life there are so many appliances that use electrical energy as an energy source. Electrical energy itself is produced by power plants (Rahmaisaputra, 2013), because the utilization of marine wealth in Indonesia and even in the world is still very lacking to be

extracted into a source of electrical energy, researchers will make a prototypes of power plants that use sea wave power.

Sea waves are the movement up and down of sea water levels with varying heights according to the energy provided by the wind as the main generator in generating sea waves (Alfiansuri & Efrita, 2014). Ocean waves have a lot of potential energy that can be utilized, one of which is to convert ocean wave energy to generate electrical energy. There are many ways to extract energy from ocean waves and many efforts have been made to categorize them. In general, the utilization of ocean waves is classified into three, that are Point Absorbers, Linear Absorbers or Attenuators and Terminators. Point Absorbers are to use of sea waves by using the movement of sea waves under the water. Linear Absorbers or Attenuators are the utilization of ocean waves by utilizing the movement up and down of sea water, and Terminators are passive utilization of sea waves by accommodating the extent of the volume of sea water so the energy produced is focused in one direction (Hayward & Osman, 2011).

The use of sea waves to generate electrical energy has been done before, one of these studies to convert sea wave energy into electrical energy is made by using springs, kriwil gears to get one direction of rotation (Wijaya & Wayan, 2010). The thrust used to rotate the dynamo comes from buoyancy or floating gravity. So in principle, the research uses a floating pendulum that is hung and connected to a gear, then the gear is connected to a dynamo using a chain to rotate it and the dynamo produced an electrical energy (Nurhadi et al., 2012).

In this study, it was designed in such a way as a prototype of a sea wave power plant with a buoy method and used a Recoil Starter as the main mover connected to the shaft and gears which would then drive the DC generator. The main electricity generation tool in making this prototype is a permanent magnet DC generator which is commonly used on scooters or bicycles as a provider of electricity in the vehicle's electrical system. Through this research will be revealed how the design of the tool to be made and how to utilize and perform the tool as a sea wave power plant.

## **2. Methods**

This research was conducted in the city of Manokwari, Province of West Papua. There are two locations for data collection, first location on Maruni Beach, South Manokwari and second on Amban Beach, North Manokwari.

### **2.1 Research Procedure**

The first stage of researchers conducts literature studies, collects supporting theories related to problems and research objectives, conducts interviews with people who are experts in the field of research to be carried out.

At the planning and design stage of the tool starting from the frame to determining the core mechanical rotation ratio or making the gearbox. After designing, the next stage is the assembly of the frame and core mechanics of the tool. Then in the next stage, there is testing the tool as well as taking data in the field.

Data collection in the field was carried out on two beaches which took approximately one week. After the data collection is complete, the researcher conducts data analysis and gets the final result in the form of calculation data.

### **2.2 Tool Design**

In making a tool, design is very important, so to make a tool must be in accordance with the objectives in this research so when testing in the field can be reduce an obstacle.

### 2.2.1 Frame Design

In this research, the generation system to be made is a generator system with a floating model so that in its design it must take into account the buoyancy strength of the buoy to be used, (Nurjati, 2015) and a sturdy frame model to withstand waves and pull from the main mover that will be connected to the ballast system during the trial.

In its manufacture, four block-shaped jerry cans with their respective sizes  $P = 20$  cm,  $L = 25$  cm and  $T = 44$  cm as buoys and hollow iron as the main frame. For more details, the frame design to be made can be seen in Figure 1. below.

In order to be able the withstand waves, the buoy is installed as in figure 2.2 and connected by a hollow iron frame with a range between the buoys that is 140 cm wide and 160 cm long so this prototype will not be overturned due to the waves. The following is the calculation of the buoyancy force of the buoy, the tool used

#### a. Buoy volume

It is known that buoys use jerry cans measuring  $P = 20$  cm,  $L = 25$  cm and  $T = 44$  cm.

Then you will get a float volume of:

$$V = W \times W \times H = 20 \times 25 \times 44 = 22000 \text{ cm}^3 \quad [1]$$

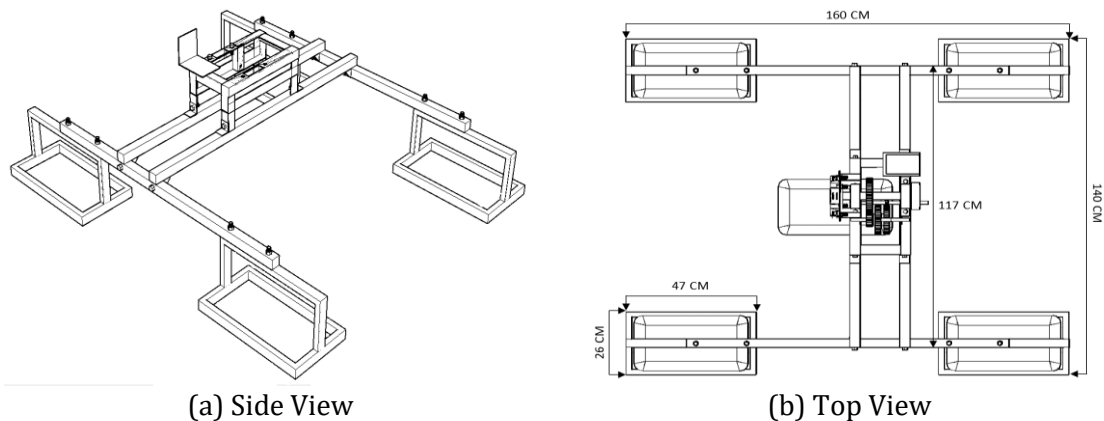

Figure 1. Design of Tool Frame

#### b. Buoyancy Force

To the calculate of buoyancy force:

$$\begin{aligned} FA &= \rho \cdot V \cdot g \\ &= 1030 \text{kg/m}^3 \times (22000 \times 4) \text{ cm}^3 \times 9.8 \text{ m/s}^2 \\ &= 1030 \text{kg/m}^3 \times ((22000 \times 4) ) / 1000000 \text{ m}^3 \times 9.8 \text{ m/s}^2 \\ &= 888.272 \text{ N or } 90.64 \text{ kg.} \end{aligned} \quad [2]$$

So, the system of buoy will be able to withstand a maximum weight of 90.64 kg above sea level.

### 2.2.2 Recoil Starter

Design and Build a Prototype of this Sea Wave Power Plant (PLTGL) using a Recoil Starter, then the main driving component in this tool is the recoil starter that rotates because the rope is attracted by the ballast caused by changes in sea wave height.

The recoil starter used is the Kabar recoil starter 5000 watts – 7000 watts (6.5HP – 9 HP) with a rope length of 120 cm, to rotate once the center shaft connected to the spur gear drive in the gearbox, requires approximately 40 cm, so with a 120 cm long rope, this starter recoil is able to rotate three times the full center shaft connected to the gearbox, (Hasan, 2021).

### 2.2.3 Gear Box

To mop the recoil rotation of the starter to the DC generator, researchers use a gearbox to change the spin moment (WikiHow, thn). The gearbox components which used consist of one spur gear with 44 gear (drive gear), two spur gear couples with 18 to 36 gear (connecting gear), one spur gear with 15 gear, one gear centric with 28 gear and a connecting chain from the centric gear to the DC generator. For the calculation of the rotation ratio of the gearbox as follows:

Before calculating the rotation ratio of the tool gearbox that has been made, consider (Fig2.) the following gear arrangement:

Fig 2.2 is the gear arrangement of the prototype gearbox of the ocean wave power plant that the researchers have made.

Entering the calculation of the rotation ratio (Close et al., 2001), as mentioned earlier, the drive spur gear has 44 gear interlocked with spur gear 18 to 36 gear. Suppose the first gear with 44 drive spur gear, second gear with 18 to 36 spur gear, third gear with 18 to 36 spur gear, fourth gear with 15 spur gear, and fifth gear 25 gear centric.

To start calculating in suppose the first gear is rotates one full turn, using calculations, then: Gear ratio =  $T1/T2 = 44/18 = 2.44$  revolutions. [3]

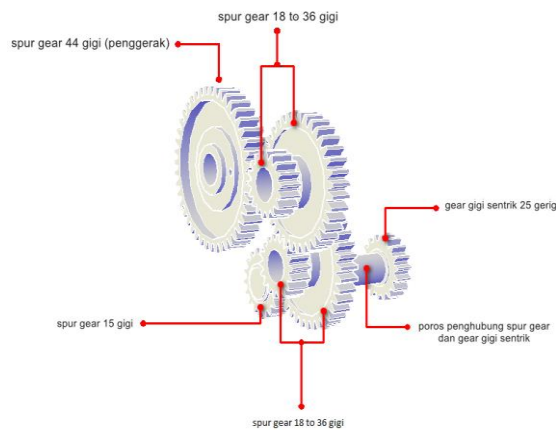

Figure 2. Gearbox Arrangement

So if first gear is spins one full turn, then second gear will spin 2.44 times. Furthermore, because second gear is a gear couple of 18 to 36 gears, then if second gear rotates 2.44 times, the rotation ratio in gear 3:

$$\text{Gear ratio} = (T2 \times 2.44)/T3 = (36 \times 2.44)/18 = 4.88 \text{ revolutions.}$$

It can be seen that if the first gear is rotates one full revolution, the third gear will rotate 4.88 times. Like second gear, third gear is also a gear couple of 18 to 36 gears, then the rotation ratio in fourth gear:

$$\text{Gear ratio} = (T3 \times 4.88)/T4 = (36 \times 4.88)/15 = 11.72 \text{ revolutions.}$$

Because of fourth gear is paired by the shaft to fifth gear, the rotation ratio of fourth gear is equal with the rotation ratio of fifth gear. So far, it has been known that if first gear is rotated once a full rotation, the rotation ratio in fifth gear or the last gear is 11.72 revolutions.

This fifth Gear will then be directly paired to the DC Generator using a chain. It is known that the rotor end of the DC generator to couple it with fifth gear uses a centric gear with nine gears, then to calculate the final rotation obtained by the generator, that is:

$$\begin{aligned} \text{One full turn of first gear} &= 11.72 \text{ turns of fifth gear,} \\ \text{DC Generator Ratio} &= (T5 \times 11.72)/(\text{number of DC generator gear}) \\ &= (25 \times 11.72)/9 \\ &= 32.5 \text{ rounds.} \end{aligned}$$

So in conclusion, if the recoil starter rope is pulled along 40 cm, or the drive gear on the gearbox rotates as much as one full turn, then the DC generator will rotate as much as 32.5 revolutions when lifted up by the sea wave and will rotate again as much as 32.5 revolutions when back down. So the total revolution obtained by the DC generator is  $32.5 \times 2 = 65$  times/1 period.

By using a 24 Volt DC generator with an average speed of 3200 rpm (revolutions per minute) producing 24 Volt and a current of 6.25 Amperes, then if the speed of the sea wave is 40 cm/s or 32.5 rps (revolutions per second), then the rpm obtained is  $32.5 \times 60 = 1950$  rpm.

The estimated rpm with a sea wave height of 40 cm with revolutions on the DC generator per second is 32.5 revolutions, to find out the rpm as calculated above is:  $32.5 \times 60 = 1950$  rpm.

### 2.3 Tools and Materials

Table 1. The Necessary Materials and Tools

No.	Tools and Materials	Function
1	Laptop	Tools to compile research results
2	Stationery	To write
3	<i>Microsoft Excel 2016</i>	To process statistical data
4	<i>AutoCAD 2019</i>	To draw
5	Camera	For documentation
6	Printer	To print research results
7	Grindstone	For cutting iron
8	Electric drill	To make bolt holes
9	Electric welding	For welding tool frames
10	Meter	To measure length
11	Screwdriver	To open and tighten nuts
12	Lock the combination of 10 cm and 12 cm	To open and tighten bolts
13	<i>Kabaru Starter Recoil 5000 watts - 7000 watts (13HP - 16 HP)</i>	As the main driving force on the tool
14	Elbow Iron	For tool frame
15	<i>Hollow Iron</i>	For float frames and mounts
16	<i>Gears, Spur Gear and centric gear</i>	For <i>gearboxes</i>
17	Kamrat chain	To connect the <i>gearbox</i> to <i>DC</i> generator
18	<i>DC</i> Generator	For voltage generator
19	Diode Bridge 3 Ampere	
20	Britch Diode / 3 Ampere comb diode	To reverse the <i>output</i> voltage potential of a <i>DC</i> generator
21	Plastic jerry cans 20L 4 pieces	For buoys
22	Rope	To fasten Anchors and tool weights

### 2.4 Observation Variables

The variables observed in this research are factors that affect the working system of the prototype of a Sea Wave Power Plant using a recoil starter that has been made. There are several things that can affect the working system of this prototyp that are, the influence of buoy area on output power, sea wave height and sea wave potential.

### 3. Results and Discussion

The prototype of the power plant using a recoil starter has been tested directly in two different coastal locations in the city of Manokwari, West Papua. The first test was on Maruni beach, South Manokwari and the second test on Amban beach, North Manokwari, (Dinas Pariwisata Kepemudaan dan Olahraga Kabupaten Manokwari, 2020). To get a comparison of different data, testing on each beach was carried out for two days.

Tabel 2. Coordinates of Tool Test Location

No.	Location	Coordinate Point
1	Maruni Beach, South Manokwari	S 00°58'00" : E 134°00'48"
2	Amban Beach, North Manokwari	S 00°48'38" : E 134° 03'41"

Source: Primary Data, 2020

#### 3.1 Design of the Tool

The overall design of the tool can be seen in Figure 3.1.

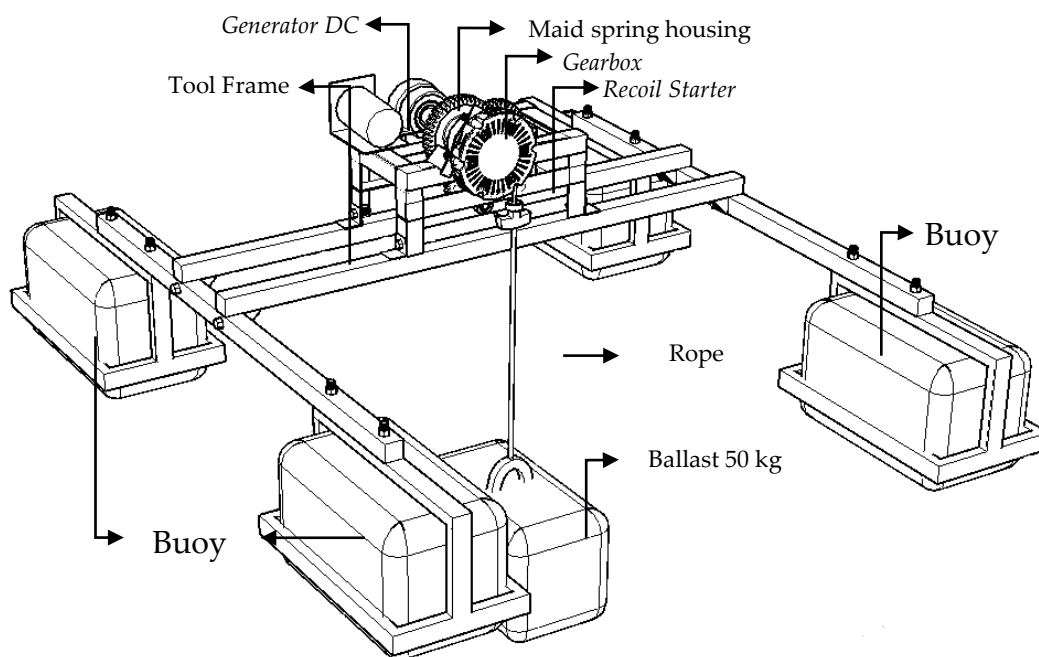

Gambar 3. Design of the Tool

After designing and drafting in this research, that is making a prototype of a Sea Wave Power Plant using a Recoil Sarter, researchers have realized and found the design as shown in (Fig 3). The design is not planned to harness the potential power of ocean waves with a large percentage of value, but will focus more on how the system works in generating its electrical energy.

### 3.2 Potential Power, Theoretical Power and Yield Power

In the data analysis section, there will be a comparison of the values of potential power, theoretical power and yield power. Therefore it is important to know what is meant by potential power, theoretical power and such result power.

#### 3.2.1 Potential Power

Potential power is an estimate of the power that can be extracted into electrical energy on the beach where the test equipment is carried out. The potential power can be calculated using the equation below. The following is an example of calculating potential power using one sample of data obtained during testing the tool on the first day of Maruni beach. The following data were obtained, (Alfiansuri, & Efrita, 2014):

$$\begin{aligned} P.E &= \frac{1}{4} \cdot w \cdot \rho \cdot g \cdot a^2 \cdot \lambda & [4] \\ &= \frac{1}{4} \cdot (0,44 \text{ m}) \times (1030 \text{ kg/m}^3) \times (9,8 \text{ m/s}^2) \times (0,02) \times (19,36) \\ &= 483,60 \text{ Joule} \end{aligned}$$

To convert into watts then:

$$\begin{aligned} P_W &= \frac{E_W}{T} & [5] \\ &= \frac{483,60}{1,94} \\ &= 248,71 \text{ Watt} \end{aligned}$$

Where (w) is the cross-sectional area of the buoy 0,44 m, ( $\rho$ ) is the density of the sea water type  $1030 \text{ kg/m}^3$ , (g) is Earth's gravity  $9,8 \text{ kg/m}^3$ , ( $a^2$ ) is the amplitude of the wave and ( $\lambda$ ) is the wave length.

#### 3.2.2 Theoretical Power

Theoretical power is an estimate of the power that can be produced by the tool based on mechanical calculations such as the multiplication between the calculation of the value produced by the tool per meter and the value of the ballast load of the tool used (CHAPTER 3 point 3.4.4). To calculate the theoretical power can multiply the value of the theoretical voltage by the theoretical current or in mathematical equations can be written:

$$P_{\text{Theoretical}} = V_{\text{Theoretical}} \times A_{\text{Theoretical}} \quad [6]$$

Where :

$$V_{\text{Theoretical}} = h \cdot 0,129$$

$$A_{\text{Theoretical}} = h \cdot 0,033$$

With :  $h$  = Wave height

0,129 = value of theoretical voltage produced by the tool per meter

0,033 = value of theoretical current generated by the tool per meter

Here is an example of theoretical power calculations using one sample of data obtained during the testing of the tool on the first day of Maruni beach. The following data were obtained:

$$h = 0,3 \text{ m} = 30 \text{ cm}$$

So :

$$V_{\text{Theoretical}} = 30 \cdot 0,129 = 3,87 \text{ V}$$

$$A_{\text{Theoretical}} = 30 \cdot 0,033 = 0,99 \text{ A}$$

So :

$$\begin{aligned} \text{Theoretical Power} &= 3,87 \text{ V} \cdot 0,99 \text{ A} \\ &= 3,83 \text{ Watt} \end{aligned}$$

### 3.2.3 Yield Power

Yield power is the power which produced directly by the tool during the trial. This yield power can change because it is directly influenced by many factors when taking data in the field. Therefore, the power value of this result cannot be based on the wave height, it could be the same wave height but different power values are obtained.

Since data collection in the field only measures voltage, current and wave height, the resulting power can be obtained by multiplying the measured of voltage by the measured of current or in mathematical equations can be written:

$$P = V \times I \quad [7]$$

### 3.3 Test Results and Analysis

Data collection was carried out in two locations, there are Maruni beach and Amban beach, because based on direct observations, the both places have the potential for large enough sea waves. The following is the power comparison data between the two locations against potential, theoretical power and yield.

#### 3.3.1 Maruni Beach Day One

- a. Comparative analysis of potential power, theoretical power and power measurement results

In (Table 3.) it can be seen that the variation in data between the theoretical power or estimated power that can be produced by the device and the actual measured power is very close. The average value of the measured power can reach more than 70% of the theoretical power, which means that the prototype that has been made is quite efficient even though it has not reached 90% or higher because this prototype is the first time it has been made and there are several influencing factors such as irregular periods of waves that cause the tool to not work optimally.

Table 3. Comparison of potential power, theoretical power and measurement results

No.	Height (m)	Potential Power (W)	Theoretical Power (W)	Yield Power (W)
1	0,3	248,71	3,83	3,90
2	0,3	248,71	3,83	2,15
3	0,3	248,71	3,83	0,93
4	0,4	510,56	6,81	4,65
5	0,3	248,71	3,83	2,64
6	0,3	248,71	3,83	2,18
7	0,3	248,71	3,83	2,18
8	0,4	510,56	6,81	5,93
9	0,4	510,56	6,81	7,54
10	0,5	891,91	10,64	9,96
<b>Σ</b>	<b>0,35</b>	<b>391,59</b>	<b>5,41</b>	<b>4,21</b>

However, for the trend value between potential power, theoretical power and yield power, the measurement results have almost the same characteristics, for more details can be seen in Fig 4.



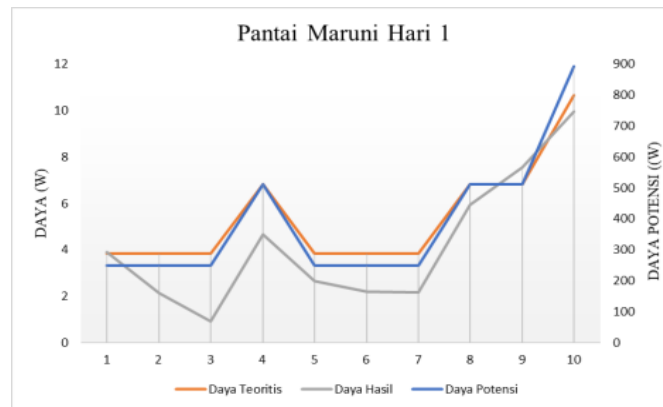

Figure 4. Comparison graph of potential power, theoretical power and yield power measurement results

b. Analysis the Comparison of Wave Height to Electrical Energy produced.

If look at the characteristics of the trend in the chart above, it can be seen that the height of the sea wave has an influence on the power produced, if the height of the wave rises then the power produced will be rise, otherwise if the wave height decreases then the power produced will be decrease. But that does not apply to some conditions such as when the period of the arrival of the wave occurs quickly, it can be seen in the graph above in the range of 1 to 3, the height of the wave remains at a height of 0.3 meters but the power produced actually decreases, it is because the period of the arrival of the wave is too fast so that in conditions like this, the tool has not returned to its normal state but is forced to work again which causes the power it produces decreased.

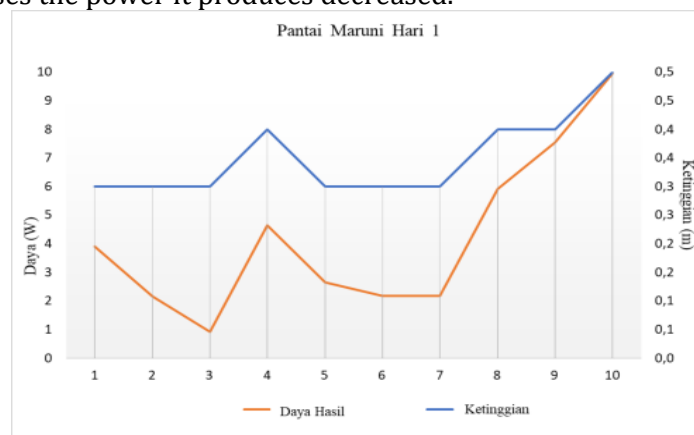

Figure 5. Graph of Wave height to Power Comparison of Measurement Results

3.3.2 Maruni Beach Day Two

a. Comparative analysis of the potential power, theoretical power and power measurement results.

Table 4. Comparison of potential power, theoretical power and measurement results

No.	Height (m)	Potential Power (W)	Theoretical Power (W)	Yield Power (W)
1	0,3	248,71	3,83	3,80
2	0,5	891,91	10,64	5,97
3	0,3	248,71	3,83	1,35
4	0,4	510,56	6,81	5,11

5	0,5	891,91	10,64	17,83
6	0,5	891,91	10,64	8,85
7	0,3	248,71	3,83	0,71
8	0,3	248,71	3,83	3,58
9	0,4	510,56	5,16	4,92
10	0,4	510,56	5,16	4,69
<b>Σ</b>	<b>0,4</b>	<b>520,22</b>	<b>6,44</b>	<b>5,68</b>

On the second day of the experiment on Maruni beach, the average wave height reached 0.4 meters and it can be seen that the comparison of theoretical power values and measured power has a smaller difference compared to experiments conducted on the first day. The average percentage between the measured power and theoretical power reached  $\pm 88\%$ , and got the highest power value of 17.83 watts exceeding the theoretical power value that had been calculated. This can happen because the wave propagation speed is high enough so that the tool receives greater torque which causes the rpm on the tool to go faster than normal conditions automatically the tool will produce large power.

Trends for potential power values, theoretical power and power measurement results can be seen in Fig 6.

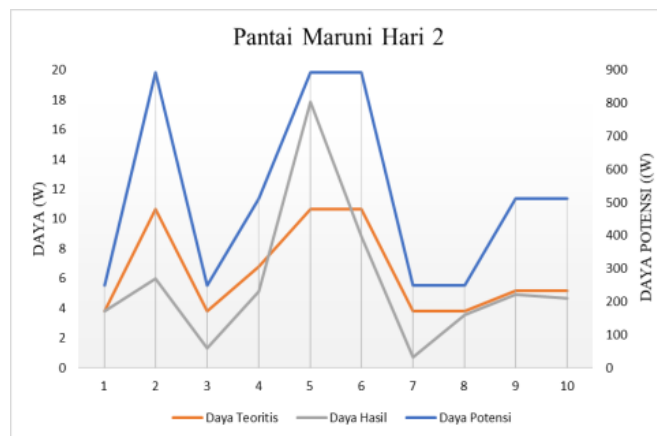

Figure 6. Comparison graph of potential power, theoretical power and power measurement results

b. Analysis the Comparison of Wave Height to Electrical Energy produced.

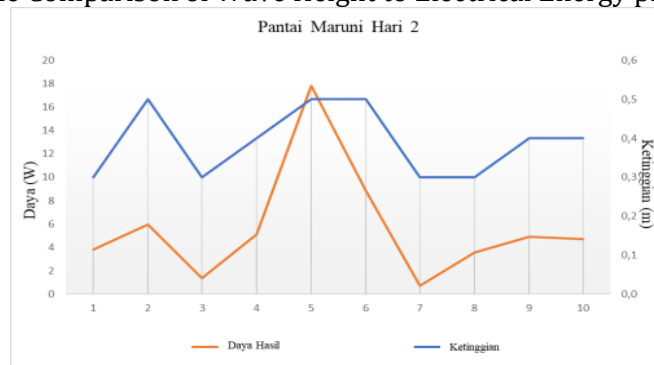

Figure 7. Graph Comparison of Wave height to Power Measurement Results

In (Fig 7.) it can be seen that the power trend line moves following the wave height trend line, when the wave rises, the power generated will rise and vice versa. This proves that the value of the power produced by the tool is directly proportional to the height of the waves.

### 3.3.3 Amban Beach Day One

- a. Comparative analysis of potential power, theoretical power and power measurement results

Table 5. Comparison of potential power, theoretical power and measurement results

No.	Height (m)	Potential Power (W)	Theoretical Power (W)	Yield Power (W)
1	0,3	248,71	3,83	3,12
2	0,5	891,91	10,64	10,54
3	0,45	685,37	8,62	4,94
4	0,3	248,71	3,83	2,05
5	0,4	510,56	6,81	2,89
6	0,4	510,56	6,81	2,90
7	0,3	248,71	3,83	1,08
8	0,3	248,71	3,83	0,82
9	0,3	248,71	3,83	0,72
10	0,4	510,56	6,81	3,86
<b>Σ</b>	<b>0,37</b>	<b>435,25</b>	<b>5,89</b>	<b>3,29</b>

Data collection on the first day at Amban beach obtained data as in the table above, the power produced by the tool looks less than optimal and the average value of power is quite far from the theoretical power value estimated to be produced by the tool. The cause is that the condition of the waves on Amban beach is irregular, the waves appear not only from the direction of the sea but appear from other sides causing strong enough sea currents to cause the ballast on the tool is always carried to the edge of the beach and the tool cannot work properly, the period of the arrival of the waves is faster than the period of the arrival of waves on Maruni beach but the drawback is that the direction of the waves that come is irregular. To find out the trend of variation in the data can be seen in Figure 8.

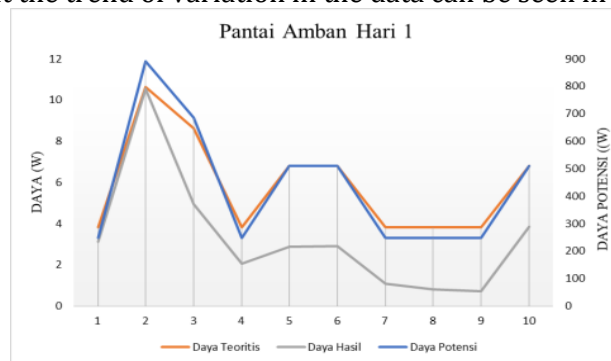

Figure 8. Comparison graph of potential power, theoretical power and power measurement results

b. Analysis of the Comparison of Wave Height to Electrical Energy produced.

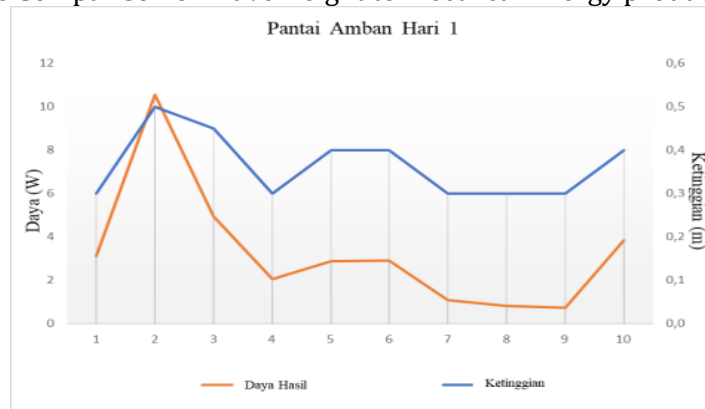

Figure 9. Graph of the comparison of Waveheight to Power Measurement Results

Until this result, the electric power is still directly proportional to the height of the sea wave obtained, this shows that the tool is working normally.

3.3.4 Amban Beach Day Two

- a. Comparative analysis of potential power, theoretical power and power measurement results

Table 6. Comparison of potential power, theoretical power and measurement results

No.	Height (m)	Potential Power (W)	Theoretical Power (W)	Yield Power (W)
1	0,5	891,91	10,64	8,97
2	0,6	1406,93	15,33	20,49
3	0,6	1406,93	15,33	24,90
4	0,5	891,91	10,64	21,89
5	0,5	891,91	10,64	9,04
6	0,7	2068,42	20,86	27,78
7	0,4	510,56	6,81	1,52
8	0,3	248,71	3,83	0,61
9	0,4	510,56	6,81	9,10
10	0,5	891,91	10,64	18,27
<b>Σ</b>	<b>0,5</b>	<b>971,97</b>	<b>11,15</b>	<b>14,26</b>

After taking data on Amban beach in the first day, researchers can study the characteristics of the waves, because Amban beach is a beach directly facing the Pacific Ocean so this beach has the characteristics of waves that are large enough. Therefore, on the second day of data collection, researchers increased the ballast load on the tool so that the tool was not carried away to the edge of the beach and the performance of the tool became better than before. Back in (Table 6.), it can be seen that variations in result data have high values and even the average power produced exceeds the average design power value. This can happen because of several influencing factors including the speed of wave propagation which is fast enough so that the tool receives torque greater than its normal value, then there is an influence on the addition of the ballast load of the tool and the period of arrival of waves on the beach is quite stable. The addition of ballast load this time can be the next reference that in addition to the height of the waves, the ballast load on the tool will also affect the results of electrical

energy, the heavier of ballast load, the better performance of the tool. To find out the trend of variation in the data can be seen in Fig 3.8.

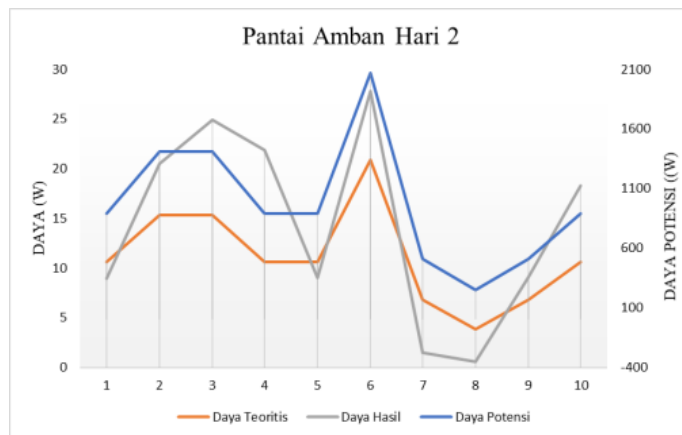

Figure 10. Comparison graph of potential power, theoretical power and power measurement results

b. The Comparison Analysis of Wave Height to Electrical Energy produced

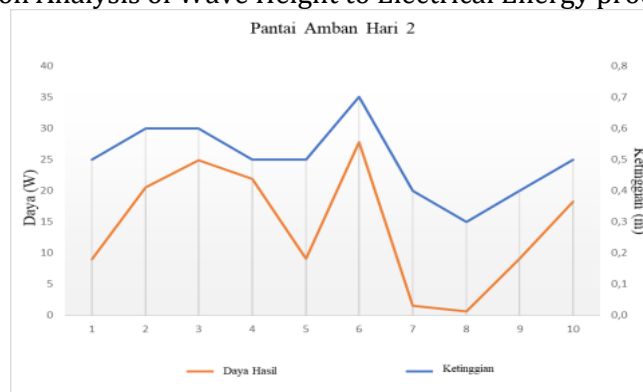

Figure 11. The Comparison Graph of Wave height to Power of Measurement Results

In the graph above, it can be seen that there is a significant fall in the power value, as previously explained that it can occur due to the period of rapid waves so that in this condition the tool cannot work optimally.

**4. Conclusions**

Based on the results of research and discussion, the following conclusions can be drawn:

1. Designing, manufacturing to the tool trial stage, it is proven that the recoil starter can be used as a drive in the prototype of a Sea Wave Power Plant.
2. In the generation of electrical energy, the period of the arrival of the waves will affect the performance of the tool, then the ballast on the tool must be taken into account, the heavier the ballast load, the better the tool will work.
3. The power output value is directly proportional to the height of the ocean wave. After measurements were made on the first day in Maruni beach, the prototype could produce an average power of 4.21 watts for an average wave height of 0.35 cm and Maruni beach on the second day could produce an average power of 5.68 watts for an average wave height of 0.4 m. While on the first day Amban beach obtained an average power of 3.29 watts for an average wave height of 0.37 cm and

Amban beach on the second day could produce an average power of 14.26 watts for an average wave height of 0.5 m.

**Acknowledgement:**

Acknowledgment is given to reviewer and IASSSF team for the support of this paper.

**Author Contribution:**

Conceptualization, F.F and H.A.B.L; Methodology, F.F; Investigation, H.A.B.L.; Resources, A.Z.P and Y.R; Writing – Original Draft Preparation, P.S and Y.R; Writing – Review & Editing, A.D.R and Y.R.P; Visualization, A.B.Z.P and P.S

**Funding:**

This research received no external funding

**Ethical Review Board Statement:**

Not applicable

**Informed Consent Statement:**

Not applicable

**Data Availability Statement:**

No new data

**Conflicts of Interest:**

The authors declare no conflict of interest

**References**

- Alfiansuri, & Efrita. (2014). Kajian Potensi Tenaga Gelombang Laut Sebagai Pembangkit Tenaga Listrik di Perairan Malang Selatan. *Jurnal Sains dan Teknologi*, 479-487.  
<https://jurnal.itats.ac.id/wp-content/uploads/2016/04/KAJIAN-POTENSI-TENAGA-GELOMBANG-LAUT-SEBAGAI-PEMBANGKIT-TENAGA-LISTRIKDI-PERAIRAN-MALANG-SELATAN.pdf>
- Arifin, A. (2020). Rumus Menghitung Volume Balok Dan Contoh Soalnya Lengkap.  
<https://rumusbilangan.com/rumus-volume-balok/>
- Close, C. M., Frederick, D. K., & Newell, J. C. (2001). *Modeling and analysis of dynamic systems*. John Wiley & Sons. <http://surl.li/jufzl>
- Dinas Pariwisata Kepemudaan dan Olahraga Kabupaten Manokwari. (2020). Pantai Amban.  
<http://pariwisata-manokwari.info/index.php/bid-odtw/destinasi-wisata/wisata-alam/wisata-kota-dan-sekitarnya/pantai-amban>
- Dinas Pariwisata Kepemudaan dan Olahraga Kabupaten Manokwari. (2020). Pantai Maruni.  
<http://pariwisata-manokwari.info/index.php/bid-odtw/destinasi-wisata/wisata-alam/wisata-kota-dan-sekitarnya/pantai-maruni>
- Hayward, J., & Osman, P. (2011). *The potential of wave energy* (Vol. 11). Report: CSIRO.  
<https://publications.csiro.au/rpr/download?pid=csiro:EP111591&dsid=DS1>
- Hasan. (2021). Beberapa Poin Penting Gearbox.  
<https://www.dutamakmurgearindo.com/beberapa-poin-penting-gearbox>
- Kho, D. (2014). Fungsi Dioda dan Cara Kerjanya.  
<https://teknikelektronika.com/fungsi-dioda-cara-mengukur-dioda/>
- Nurhadi, A., Sukmadi, T., & Karnoto, K. (2012). *Perancangan Generator Putaran Rendah Magnet Permanen Jenis Fe Fluks Aksial* (Doctoral dissertation, Diponegoro University).  
<http://eprints.undip.ac.id/32530/>

- Nurjati, D. P. (2015). Pengertian Pelampung. <https://www.pramudito.com/pelampung.html>
- Pratama, D., Rosalinda, I. A., Nurhayati, S., & Prastiwi, W. (2017). WIDURI. <https://widuri.raharjo.info/index.php?title=Prototipe>
- Rahmaisaputra, Y. (2013). Realisasi Sistem Pembangkit Listrik Tenaga Ombak. Bandung: Universitas Telkom. <https://repository.telkomuniversity.ac.id/pustaka/134476/realisasi-sistem-pembangkit-listrik-tenaga-ombak.html>
- Sulasno. (2013). Teknik Konversi Energi Listrik dan Sistem Pengaturan. Yogyakarta: Graha Ilmu. <https://oneseach.id/Record/IOS3239.slims-78795?widget=1>
- Syukroni, M. F. (2017). Rancang Bangun Knowledge Management System Berbasis Web Pada Madrasah Muallimin Al-Islamiah Uteran Geger Madiun (Doctoral dissertation, Universitas Muhammadiyah Ponorogo). <http://eprints.umpo.ac.id/3019/>
- Wijaya, I. W. A., & Wayan, I. (2010). Pembangkit listrik tenaga gelombang laut menggunakan teknologi oscilating water column di Perairan Bali. *Majalah Ilmiah Teknik Elektro*, 9(2), 165-174. <https://ojs.unud.ac.id/index.php/JTE/article/view/3153>
- WikiHow. (t.thn.). Cara Menentukan Rasio Roda Gigi. Diambil kembali dari WikiHow: <https://id.wikihow.com/Menentukan-Rasio-Roda-Gigi>.
- WikiHow. (t.thn.). Cara Menghitung Gaya Apung. Diambil kembali dari WikiHow: <https://id.wikihow.com/Menghitung-Gaya-Apung>
- Wikipedia. (t.thn.). Terjemahan dari Inggris ke Indonesia. Diambil kembali dari Wikipedia.com: [https://en.m.wikipedia.org/wiki/Rope\\_start](https://en.m.wikipedia.org/wiki/Rope_start)